

BASIC GENERIC ROBOT

Updated 2008

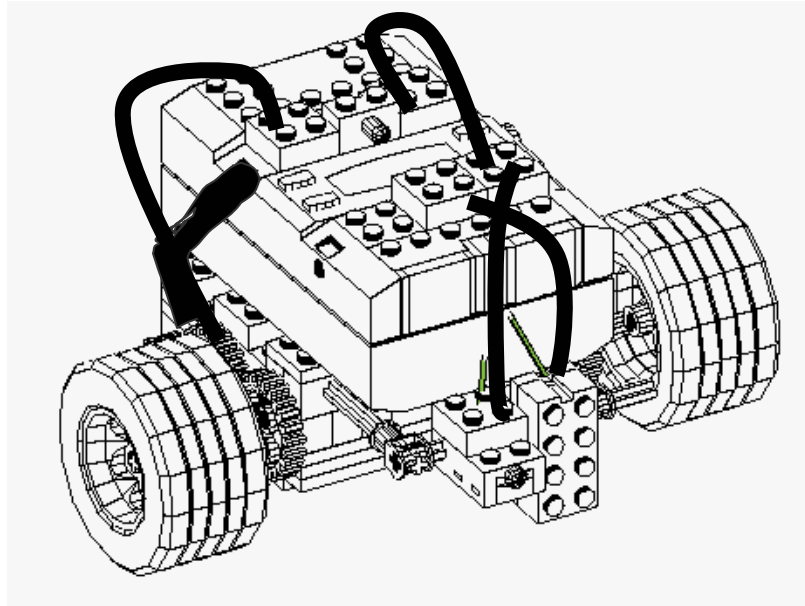

Suggested Building Sets : LEGO® MINDSTORMS for Schools Team Challenge/ Core/ Starter Set

LEGO ELEMENTS REQUIRED : Colour is un important. Substitutions may be made according to what is in your set.

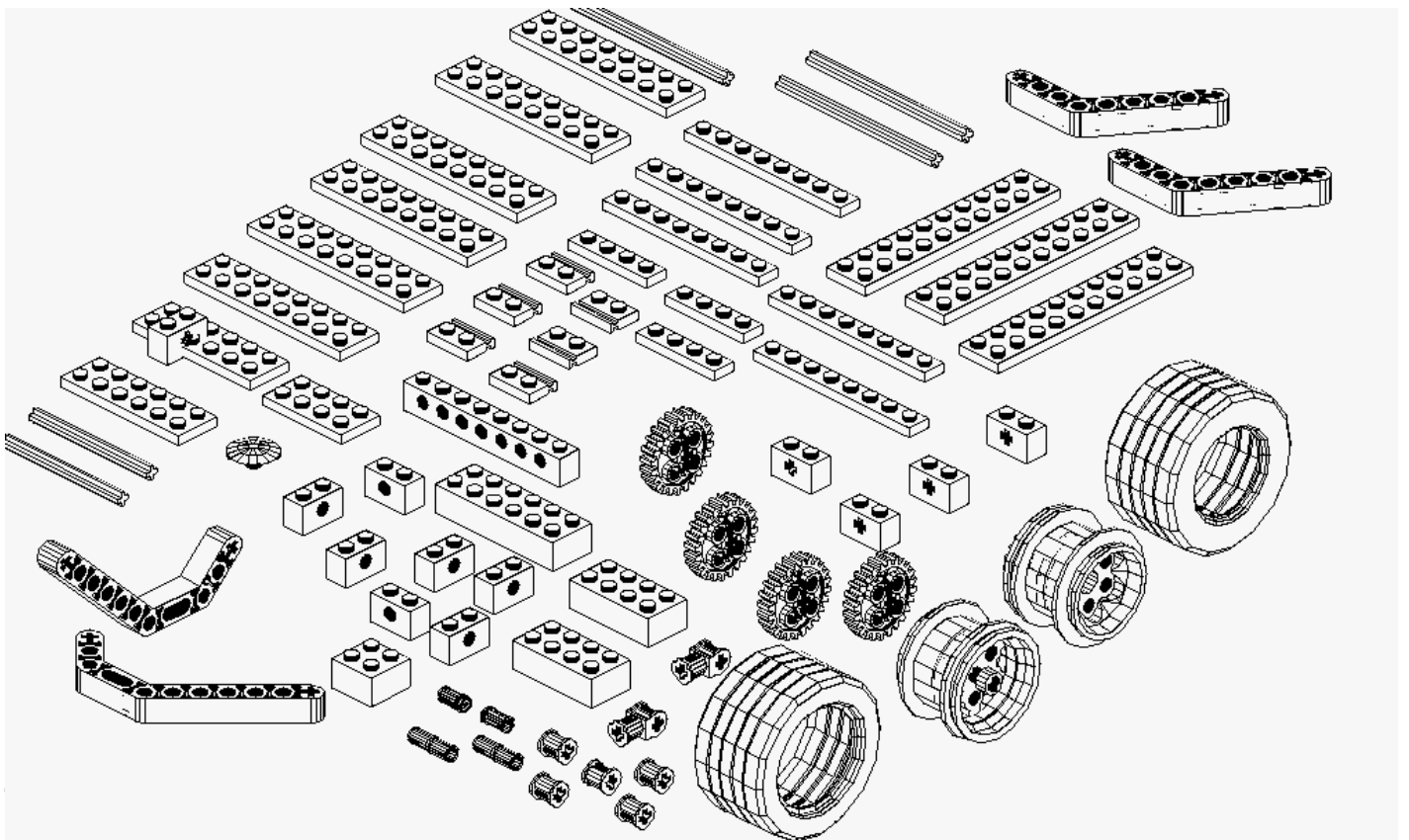

LEGO ELECTRICAL ELEMENTS REQUIRED:

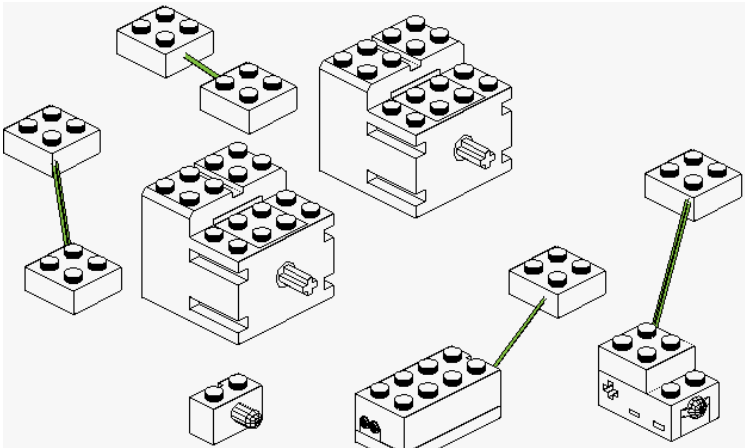

Views of the Robot :

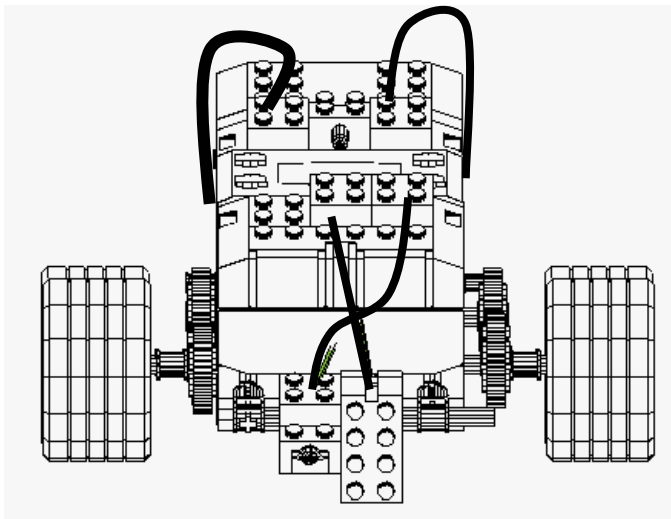

Front elevation

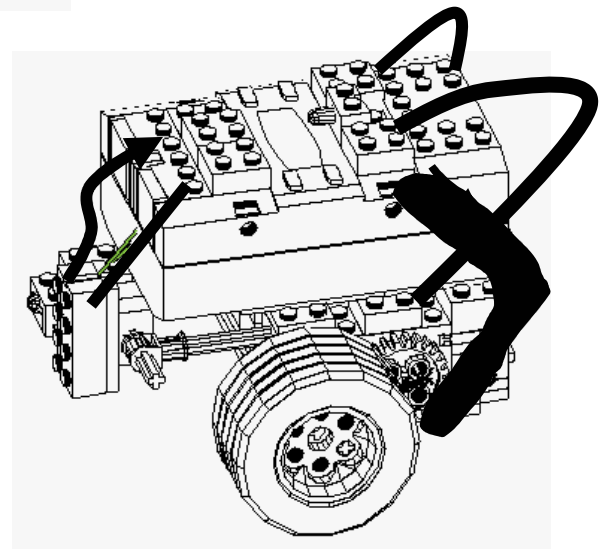

Side elevation showing the angle lever connected to the axle on through the chassis and the short connector pegs on the RCX. This provides strength

Front elevation shows touch sensor and light sensor mounted on front bar.

Note : wheels are mounted at the front of the robot.

The front “bumper” secures the touch sensor and provides a mounting for the light sensor

1

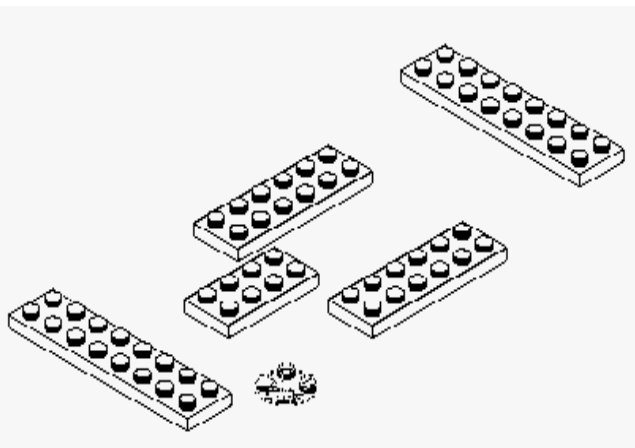

Notes: For durability the basic chassis may be glued. Superglue works well (safety precautions must be taken) . Do NOT glue in the motors. Glue elements up to step 16 if required. Wheel axles with bushes must be glued and inserted at step 5, see step 38 for gluing hints.

This clever plate is used to secure the motors into your robot.
They slide into
The grooves on either
Side of your motors
See step 6

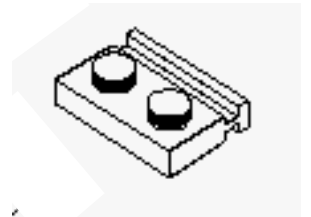

2

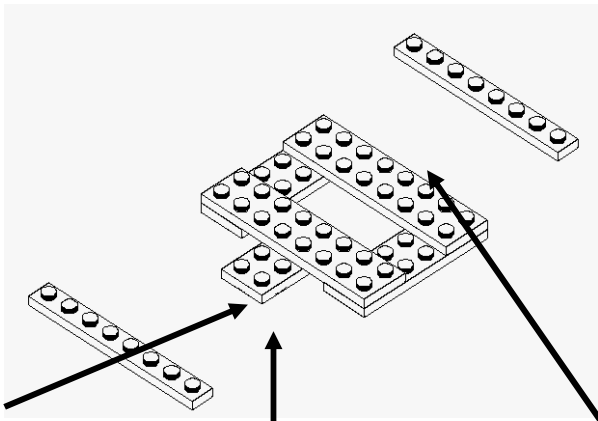

Back
front

3

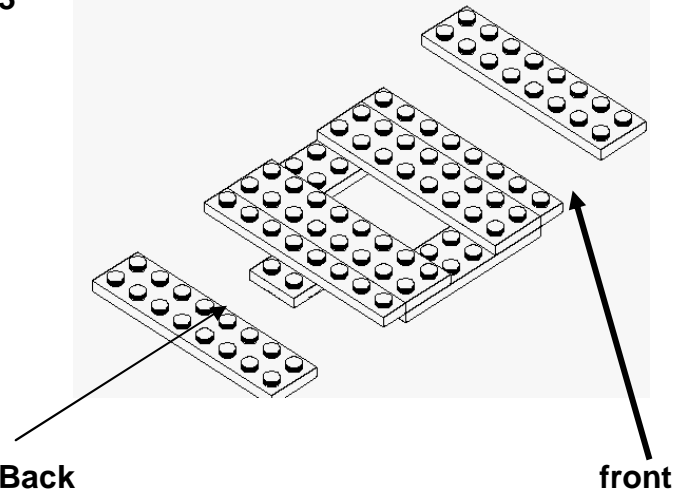

Back

front

4

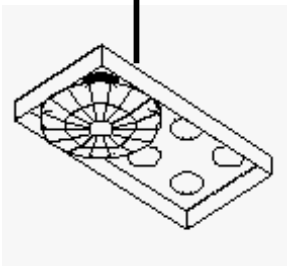

This is the skid plate, it is clipped on the underside of the back 4 x 2 plate

Before step 5 undertake the [MOTORS worksheet](#)

i.e. Benchmark your motors – place motors with equal performance in your robot

5

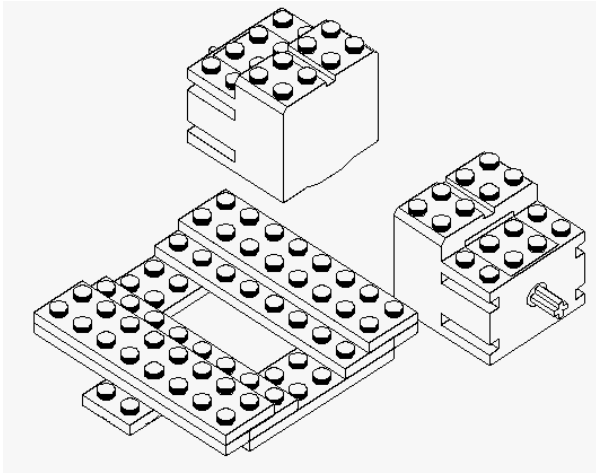

6

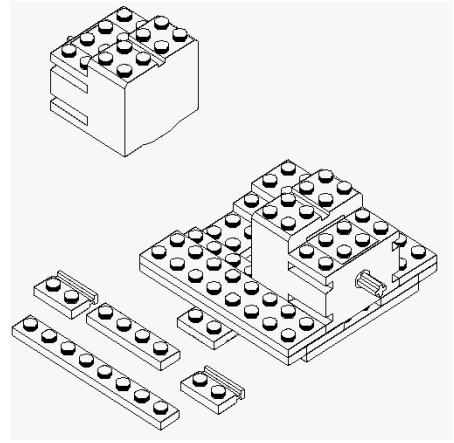

7

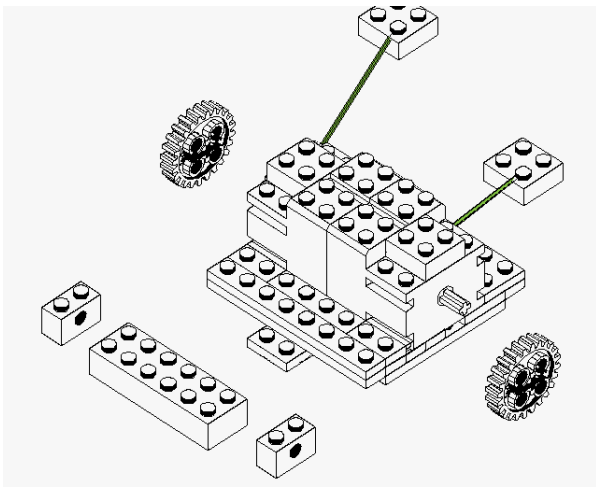

8

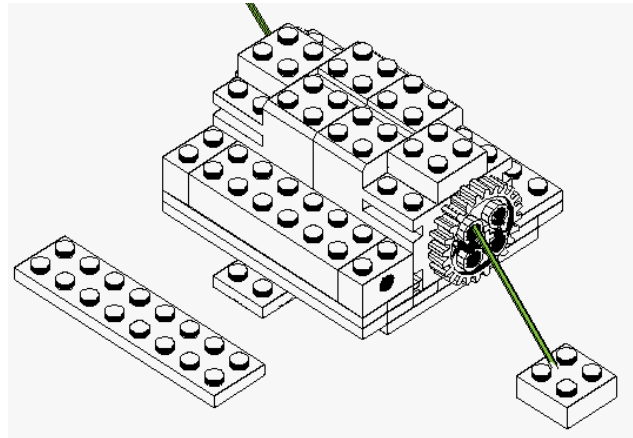

9

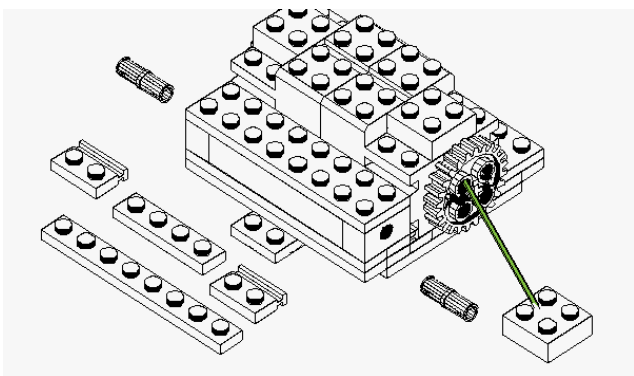

10

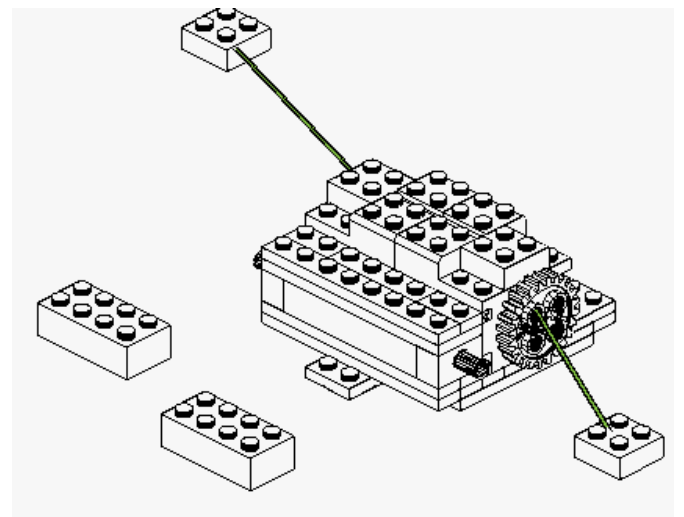

11

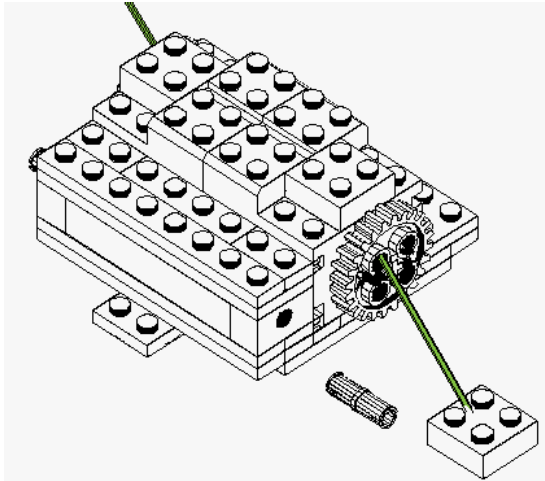

12

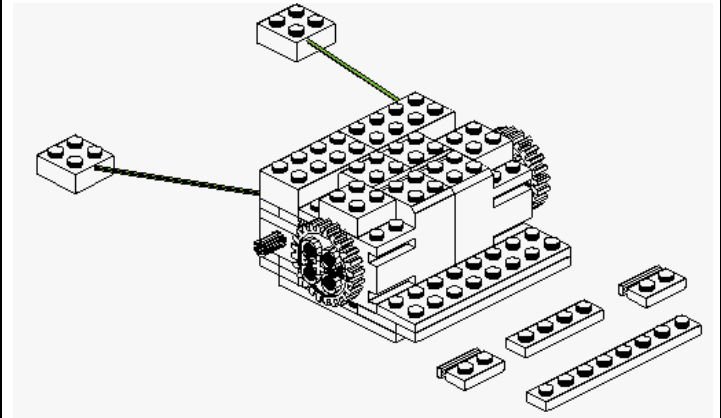

13

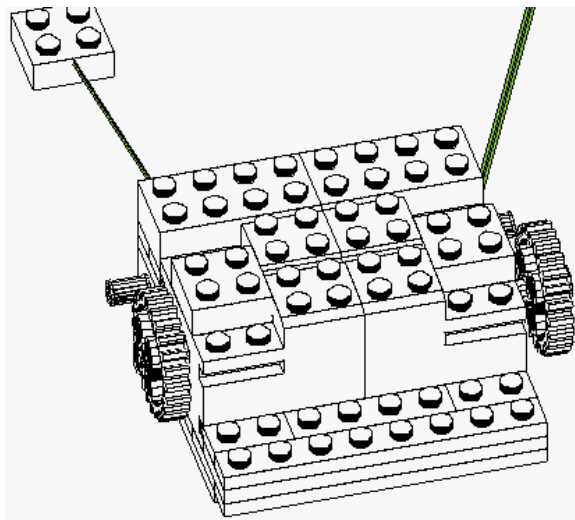

14

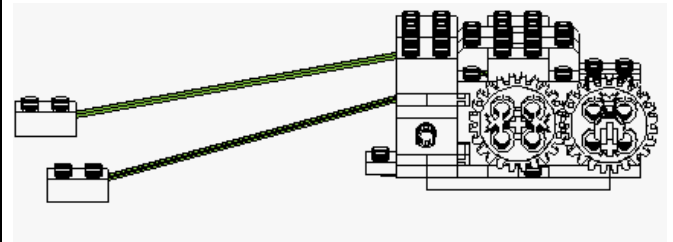

15

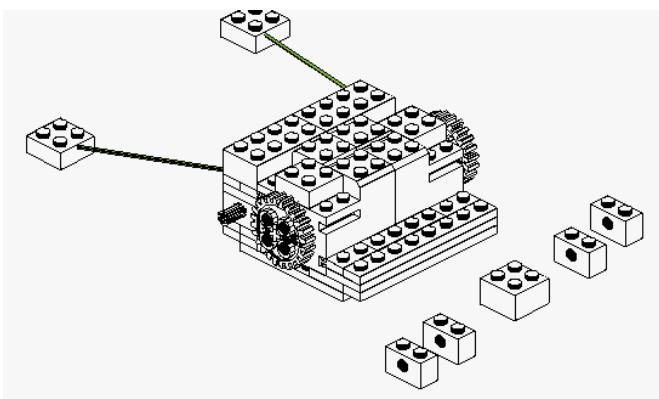

16 Glue bushed to axles and insert axles here – see step 25

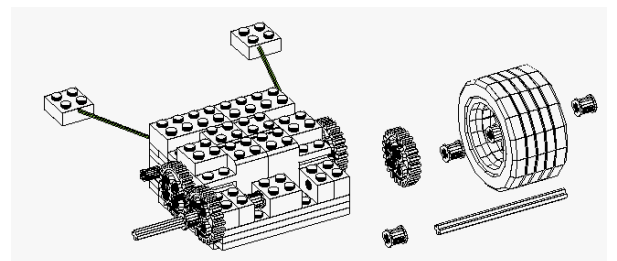

17

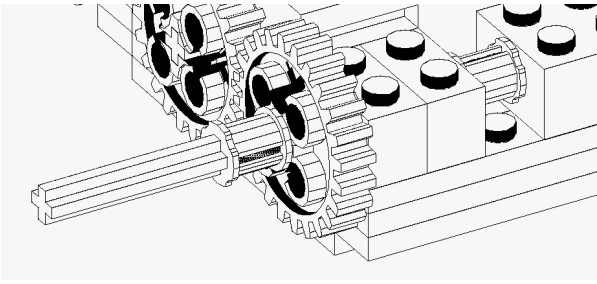

18

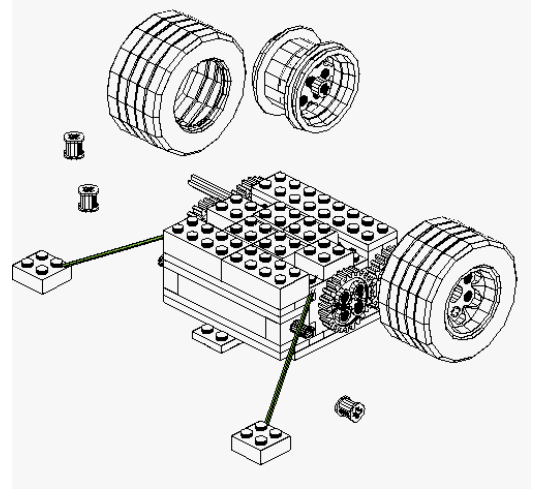

19

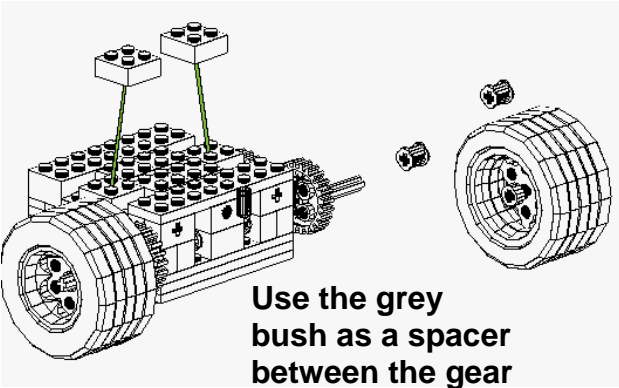

20

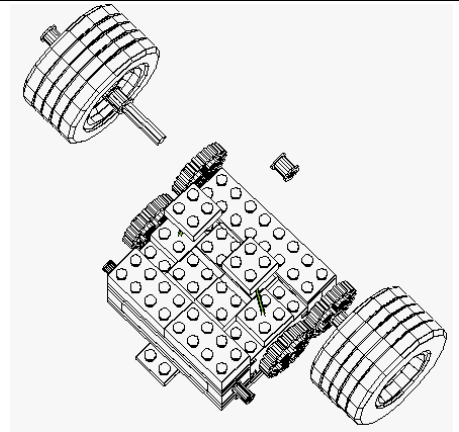

21

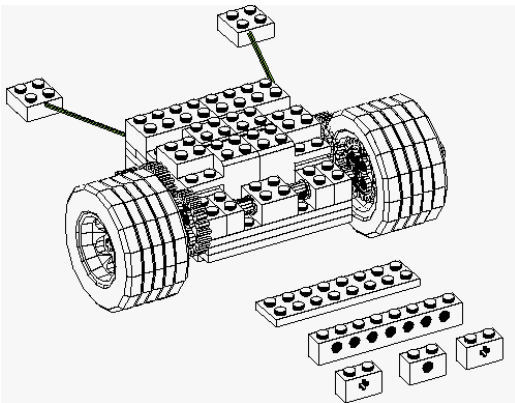

22

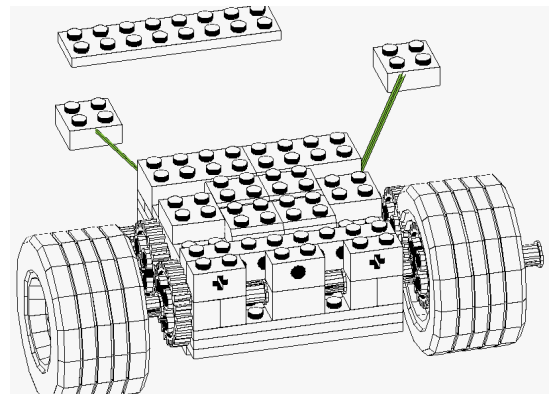

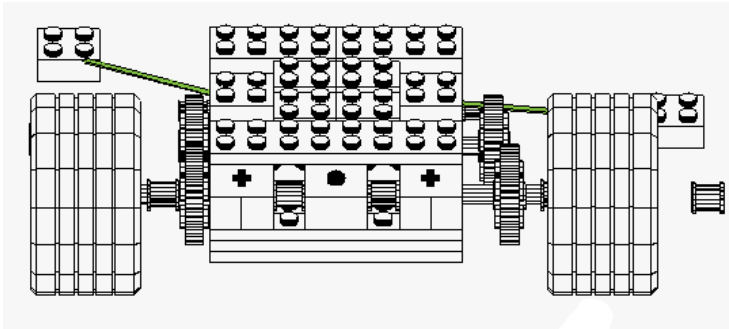

23

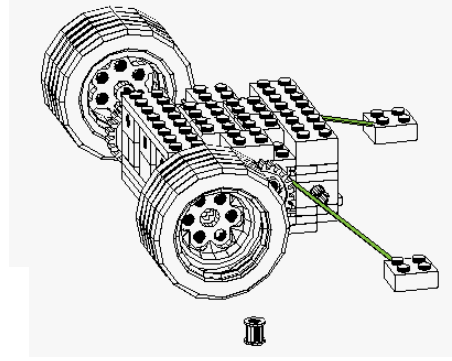

24

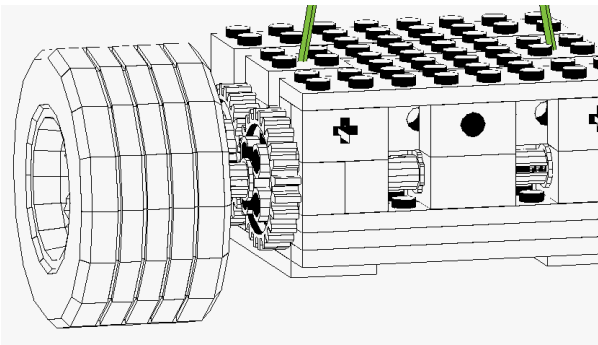

25

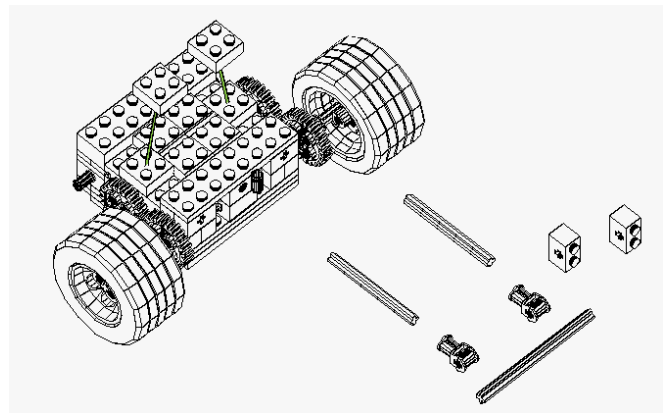

26 These bricks have axle holes. This is where you place the light sensor

27 Use the axle hole in the touch sensor to thread it onto the front "bumper axle"

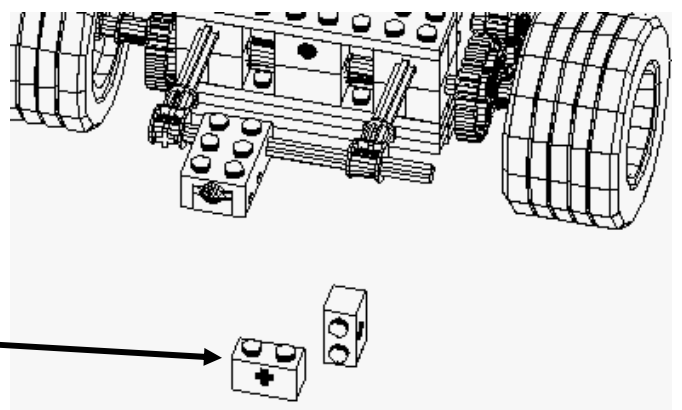
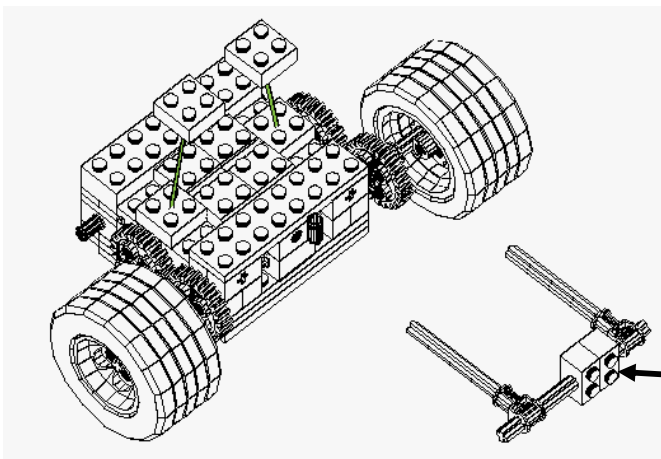

28

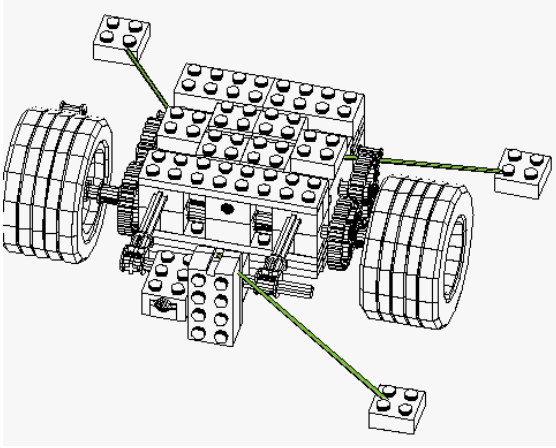

29 These plates are where you place the RCX

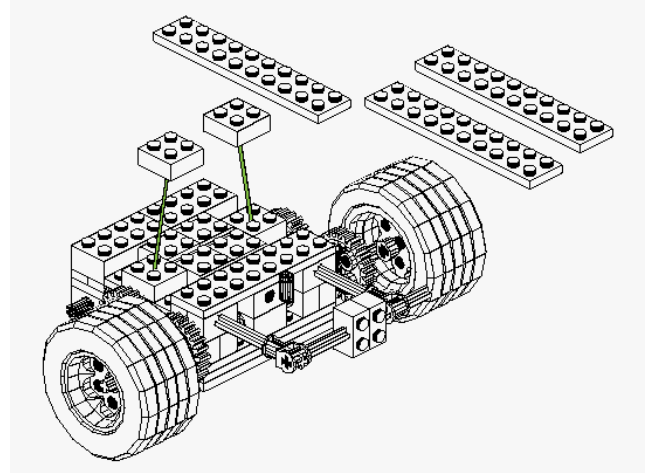

30

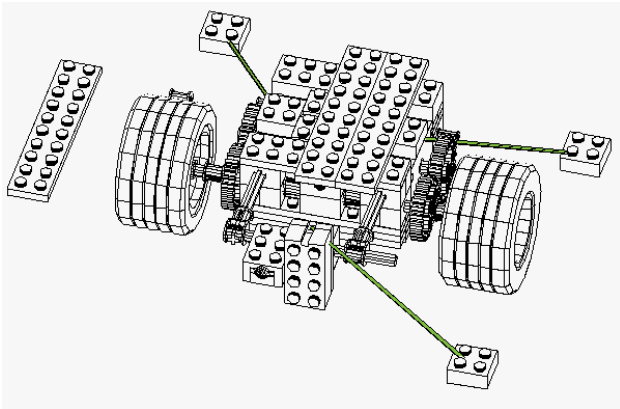

31

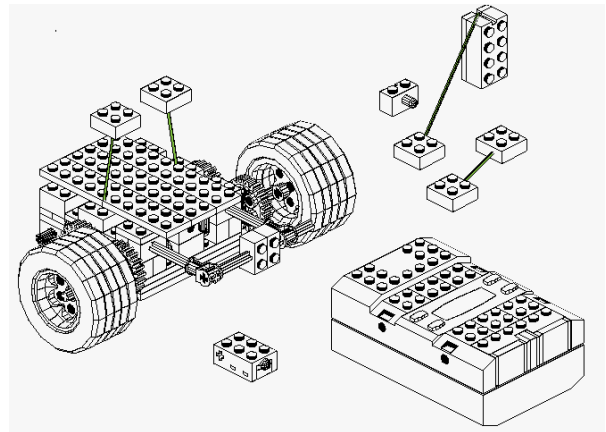

32

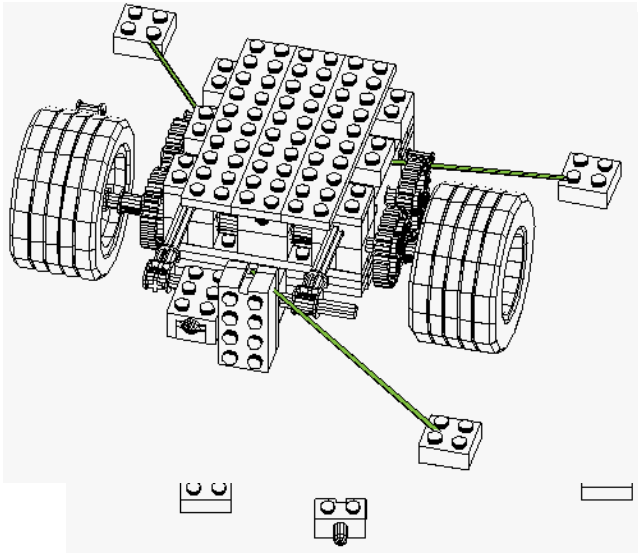

33 See Plug-in Plan #37 for ports for electricals
Electric wires have been excluded from views 33 to 36 as they obstruct the building plan views

34

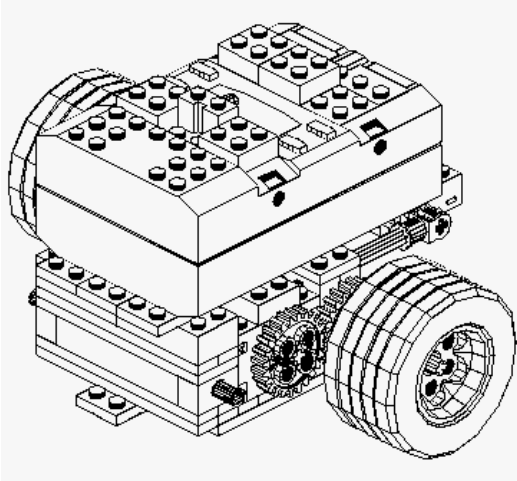

35

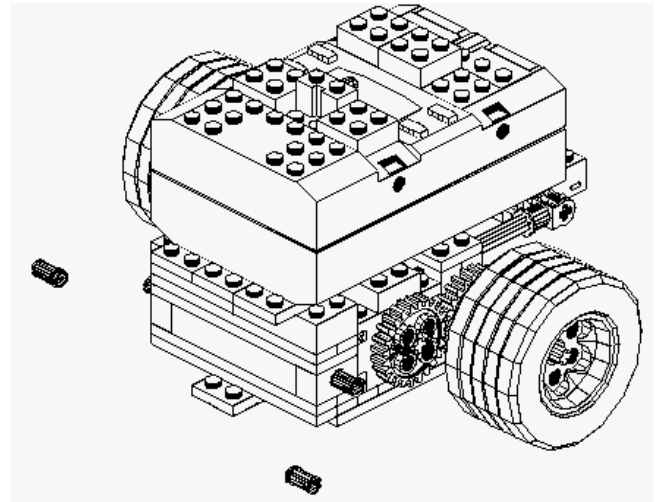

36

These 2 curved beams may
Require some manipulation
**to fit them onto the 2
connector pegs** This
prevents the battery bay
of the RCX falling off
the top of the RCX

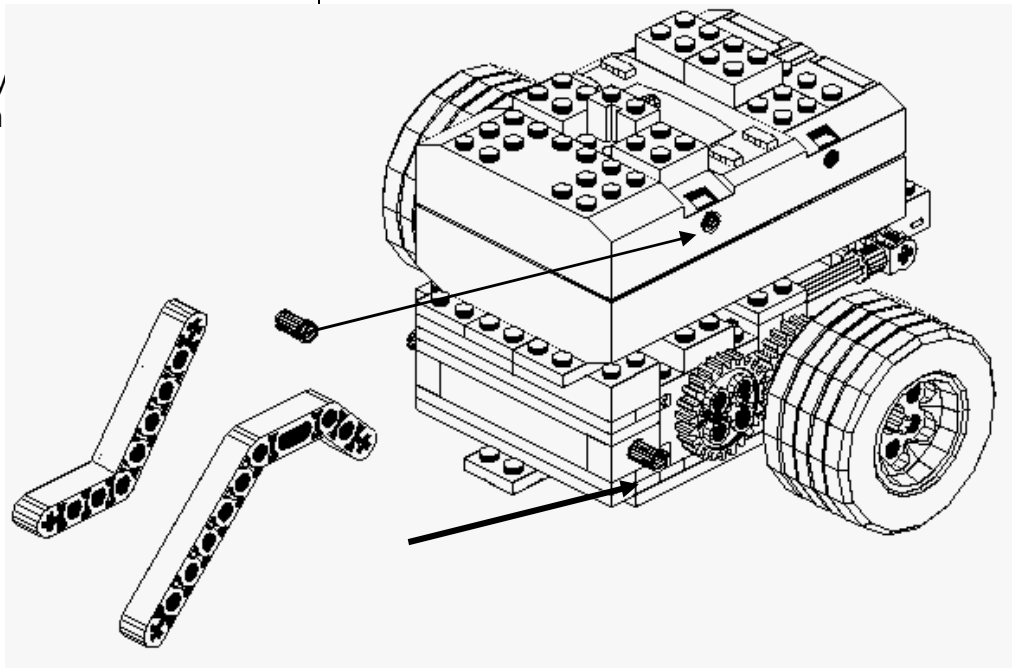

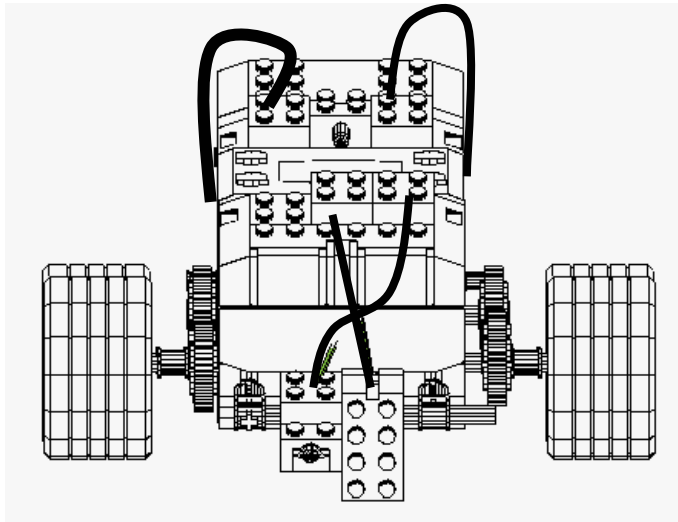

37 PLUG IN PLAN FOR ELECTRICALS

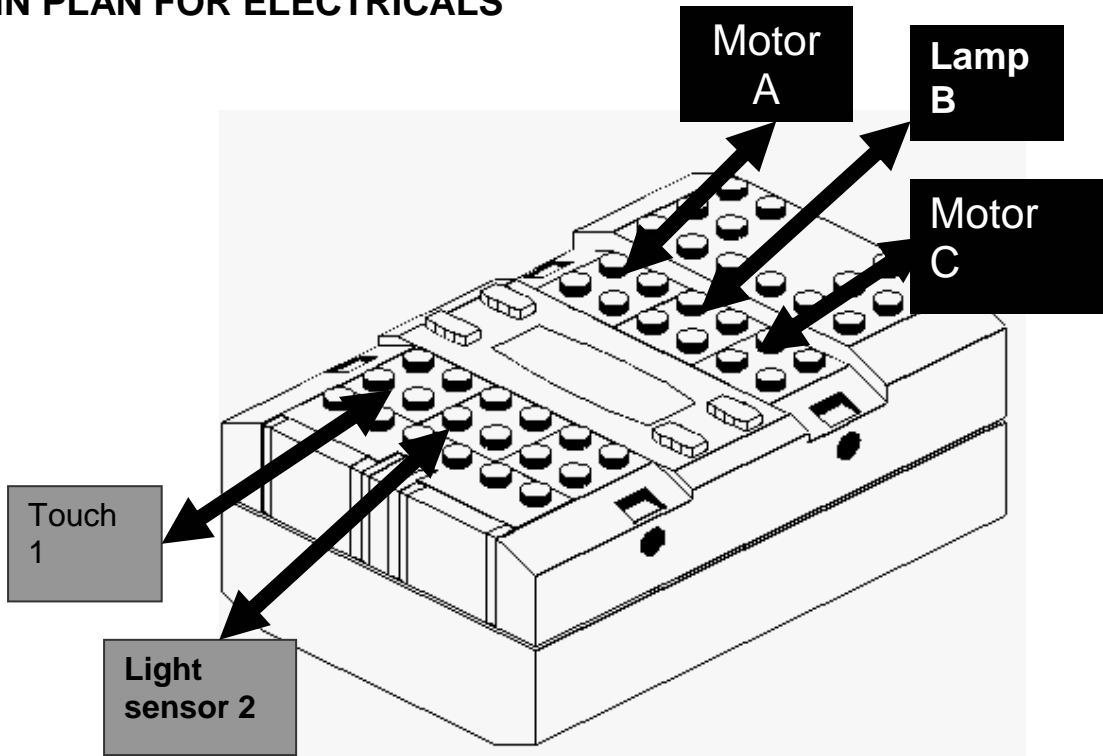

38

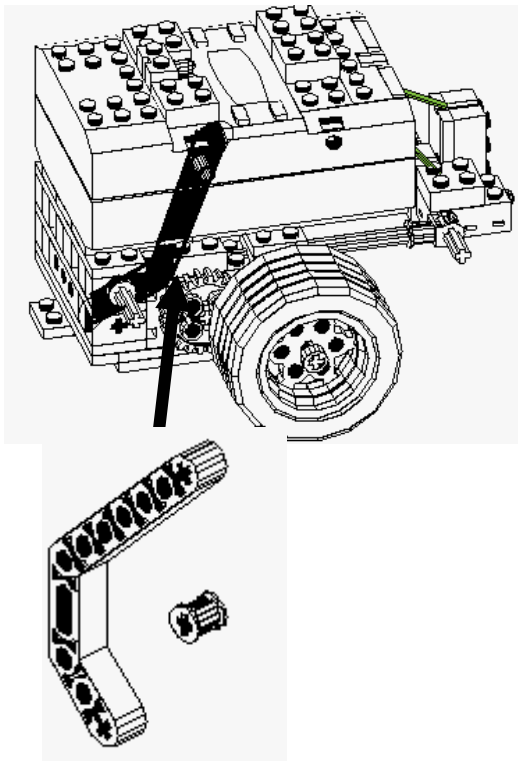

The double angle beam provides strength and stops the RCX from falling off the chassis. Rotate the beam until it fits onto the axle and connector peg. You may need to try a few variations to achieve this. Then place a grey bush on the axle to hold the beam on the model

39

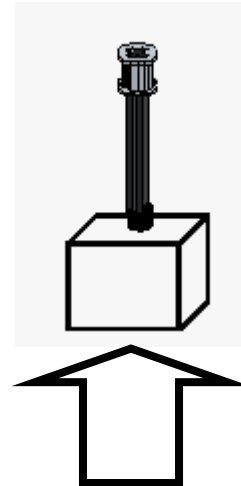

Stab the axle into a block of polystyrene to hold it vertically while the super glue dries under the grey bushing

If super-gluing this model prepare the 2 wheel axles first. Glue the bush on the axle and sure that it is dry prior to inserting axle in step 5.

Variations in performance (speed) can be achieved by using different combinations and reversing the sequence of the gears used.

Motor>

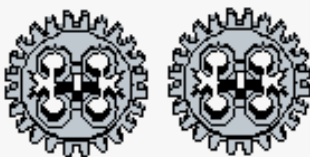

Gear Options

2 x 24 tooth

Motor>

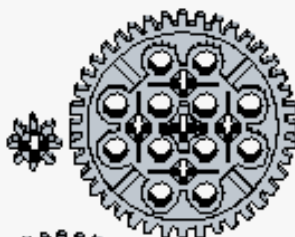

8 tooth to 60 tooth – gear down

Motor>

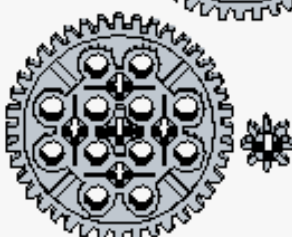

60 tooth to 8 tooth- gear up

[Gearing worksheet](#)

BUILDING AND ELECTRICAL ELEMENTS USED IN THIS MODEL

Note- Colour of element is unimportant. It is possible to make some element substitutions

Element	Number required per robot
RCX Brick	1
LEGO connecting wires	3
9V Motors 5225	2
Light Sensor	1
Touch sensor	1
Lamp element	1
Balloon Lawn tyre plus	2
Hub for Balloon lawn tyre	2
Gears – 24 tooth (or see above for alternative combinations)	4
Axles – 8 stud	3
Axle- 6 stud	2
1 X 2 plate with slider (connects into motors)	6
Brick 1 x 2 with axle hole	5
Brick- 1 x 2 with hole	7
Brick 2 x 2	1
Brick 2 x 4	2
Brick 2 x 6	1
Bushing – catch combo	2
Beam 1 x 8 with holes	1
Black skid plate	1
Double angle beam (or triple angle beam)	2
Grey bushing	5
Short grey connecting peg	2
Connector peg 1.5mm	2
Plate 2 x 4	1
Plate 1 x 4	3
Plate 2 x 6	2
Plate 2 x 8	6
Plate 1 x 8	5
Plate 2 x 10	3